

QBD series Pockels cell driver

User manual

Warning! This equipment produces high voltages that can be very dangerous.
Please read user manual before starting operations.

Important note: please measure the output with symmetrical (differential) high voltage probe only. Measurement made with inappropriate equipment is a common cause of driver's failure.



Overview

QBD series Pockels cell drivers produce high voltage pulses with high repetition rates, fast risetimes (falltimes) and adjustable voltage amplitude. Drivers are available in two modifications: QBD-DN for pull-down scheme and QBD-UP for push-up scheme. Two control types are available: manual and automatic

Pulse parameters

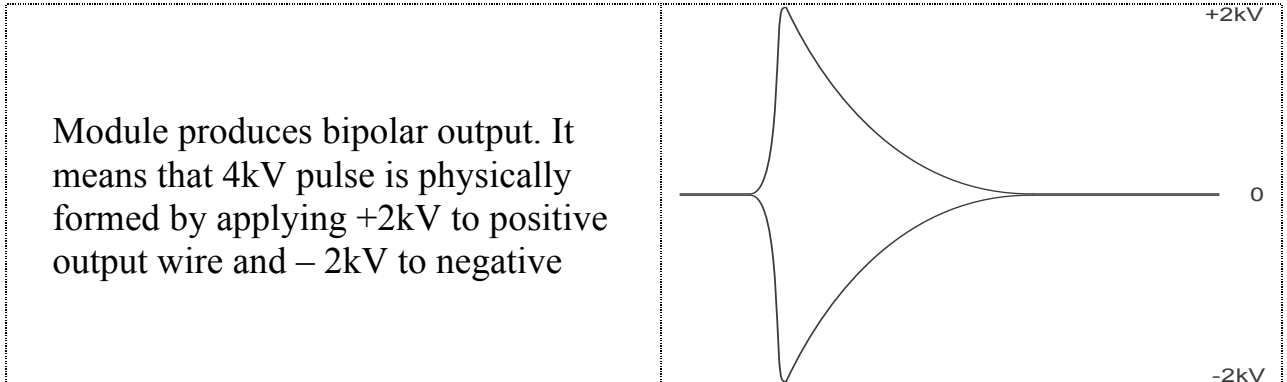

Attention! Further description of HV output will be given in terms of voltage differences. Please keep it in mind!

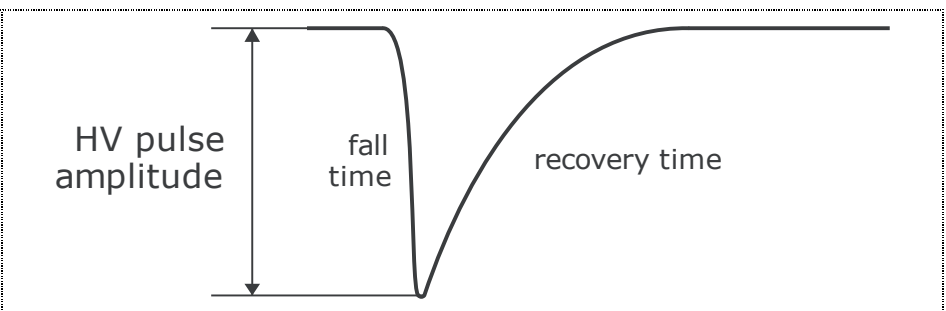
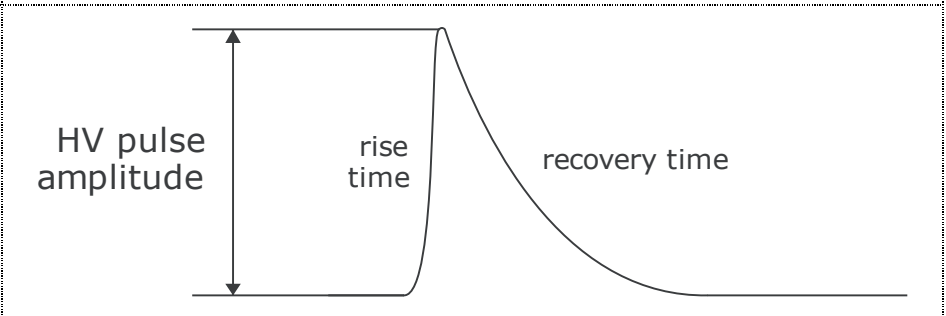
<p>Typical pulse shape (QBD-DN modification)</p>	
<p>Typical pulse shape (QBD-UP modification)</p>	
<p>Risetime/Falltime</p>	<p><20 ns ^{1,2}</p>
<p>Recovery time ²</p>	<p>5-10 us (depends on load capacitance)</p>
<p>HV pulse amplitude</p>	<p>from HVmin to HVmax ³</p>
<p>Repetition rates</p>	<p>from single shot to ~100 kHz ²</p>

¹ at 10-90% level

² depends on HV pulse amplitude and load capacitance

³ HVmin and HVmax values see in part number table

Connections, signals, signal descriptions

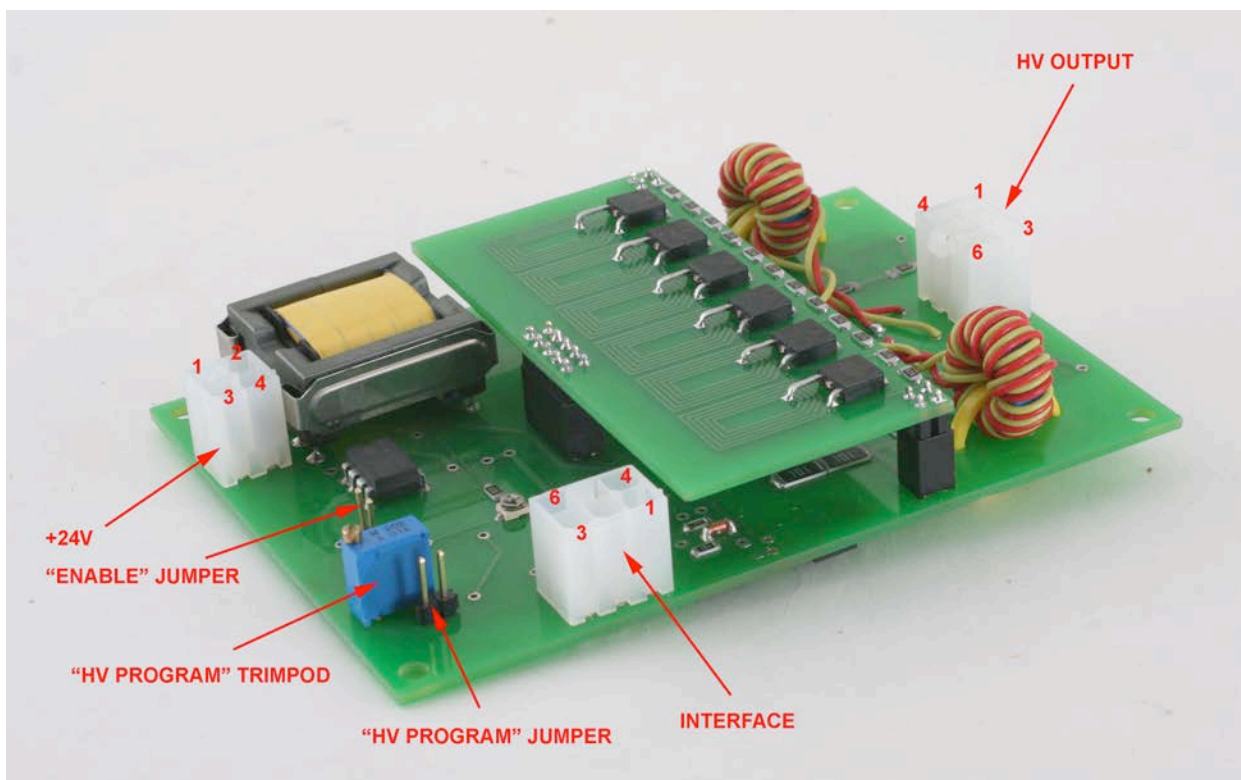

There are three connectors at Pockels cell driver board. Hereafter is description of corresponded female connectors (supplied with the board)

“ENABLE” JUMPER:

Use “*ENABLE*” *JUMPER* instead of “*ENABLE*” *PIN3* of *INTERFACE*. Don't use “*ENABLE*” *JUMPER* and “*ENABLE*” *PIN* at the same time.

“HV PROGRAM” JUMPER AND “HV PROGRAM” TRIMPOD:

Use “*HV PROGRAM*” *JUMPER* instead of “*HV PROGRAM*” *PIN6* of *INTERFACE*. If jumper is on it sets output voltage according to “*HV PROGRAM*” *TRIMPOD* state.
Don't use “*HV PROGRAM*” *JUMPER* and “*HV PROGRAM*” *PIN* at the same time.

+24V (Molex 39-30-1040):

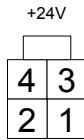

PIN (color)	DESIGNATION	DESCRIPTION
1, 2 (red)	+24V	INPUT positive 24VDC for turn on the Pockels cell driver Regulation: 22-28V, typical
3, 4 (black)	RETURN	Return from power supply producing +24VDC

INTERFACE (Molex 39-30-1060):

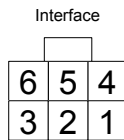

PIN (color)	DESIGNATION	DESCRIPTION
1 (orange)	Q-switch	Step from “0” or ”1” on PIN1 forms Q-Switched pulse on Pockels Cell
2, 4 (black)	Interface Return	PIN2 and PIN4 are connected to the circuit ground of all internal circuits
3 (blue)	Enable	The high voltage output is enabled by PIN3 (“1” – enable, “0” – disable)
5 (purple)	HV Monitor	The voltage at PIN5 is a monitor signal proportional to the measured value of high voltage output HVmax corresponds to 10V at PIN5, HVmin corresponds to approx. 4V at PIN5
6 (yellow)	HV Program	Positive DC voltage applied to PIN6 sets up high voltage value HV HVmax corresponds to 10V at PIN6, HVmin corresponds to approx. 4V at PIN6

“0” means logical 0 low level (0V), “1” means logical 1 high level (5V)

INTERFACE CIRCUITS

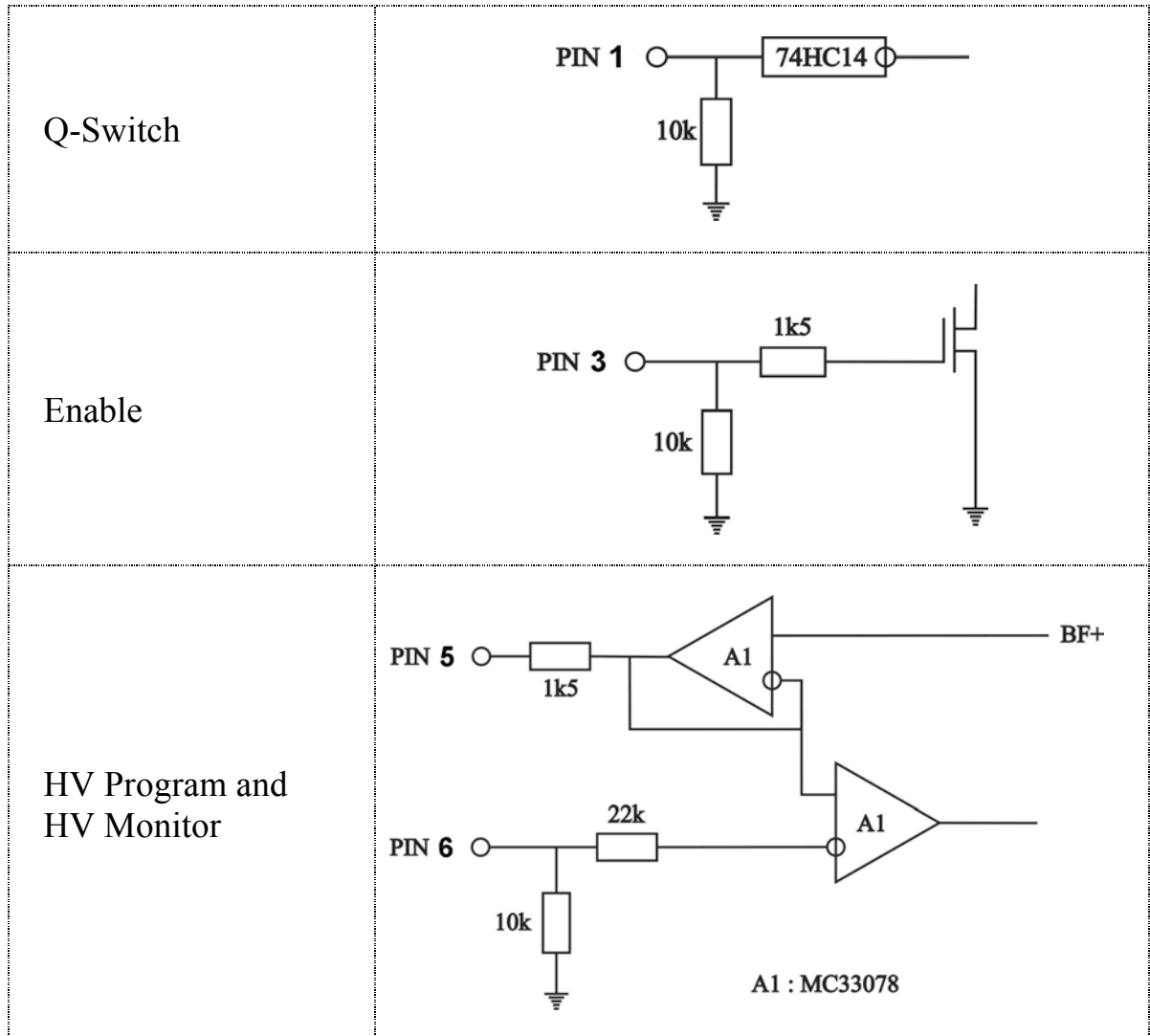

HV OUTPUT (Molex 39-30-1060):

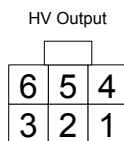

QBD-series, UP-modification			QBD-series, DN-modification		
PIN (color)	DESIGNATION	DESCRIPTION	PIN (color)	DESIGNATION	DESCRIPTION
1 (blue)	Negative	HV Negative	1 (red)	Positive	HV Positive
2-5	N/C		2-5	N/C	
6 (red)	Positive	HV Positive	6 (blue)	Negative	HV Negative

Safety

Warning! This equipment produces high voltages that can be very dangerous. Don't be careless around this equipment.

- To provide safety the QBD-series Pockels cell driver module is designed to be powered with supply voltage +24VDC, which must be galvanically separated from mains.
- It is the user's responsibility to ensure that personnel are prevented from accidentally contacting the QBD-series Pockels cell driver module, especially the high voltage connector and cable. **Casual contact could be fatal.** Output cables must have good isolation for output voltage and low capacitance.
- After shut down, do not touch the load until it has been discharged. Use an appropriate measurement device to check for complete discharge.
- Disconnect the QBD-series Pockels cell driver module from DC power supply before changing electrical or mechanical connections.

Operations (Manual control)

1. Connect +24VDC power supply, pulse generator and Pockels cell
2. Set up "*HV PROGRAM*" JUMPER
3. Turn on +24VDC power supply
4. Set up "*ENABLE*" JUMPER
5. Use "*HV PROGRAM*" TRIMPOD to set up required output voltage
6. Send driving pulses from pulse generator to *PINI* of *INTERFACE*
7. To power down the driver, turn off +24VDC power supply or remove "*ENABLE*" JUMPER

Operations (Automatic control)

1. Connect +24V, *INTERFACE* and *HV OUTPUT* connectors to the board.
2. Remove "*HV PROGRAM*" JUMPER, remove "*ENABLE*" JUMPER
3. *DISABLE* the high voltage output
4. Apply the correct nominal *DC INPUT* power to the module
5. Set up the required output voltage by applying a DC voltage to the *HV PROGRAM PIN6* of *INTERFACE*
6. *ENABLE* the high voltage output
7. Send driving pulses to *PINI* of *INTERFACE*
8. To power down the driver, remove *DC INPUT* power or *DISABLE* high voltage output

Specification

ELECTRICAL SPECIFICATION

Input	+24V DC; 0,8A max
Output	
Risetime/falltime	<20ns (depends on load)
Recovery time	depends on load (5-10us typ.)
HV pulse amplitude	see Part number table
Repetition rate	up to 100kHz
Environment	
Operation Temperature	+10...+40C (wider temperature range available on request)
Storage Temperature	-20...+60C
Humidity	90%, non-condensing

MECHANICAL SPECIFICATION

Size (LxWxH)	110x80x25 mm
Weight	0,1 kg

DRAWINGS

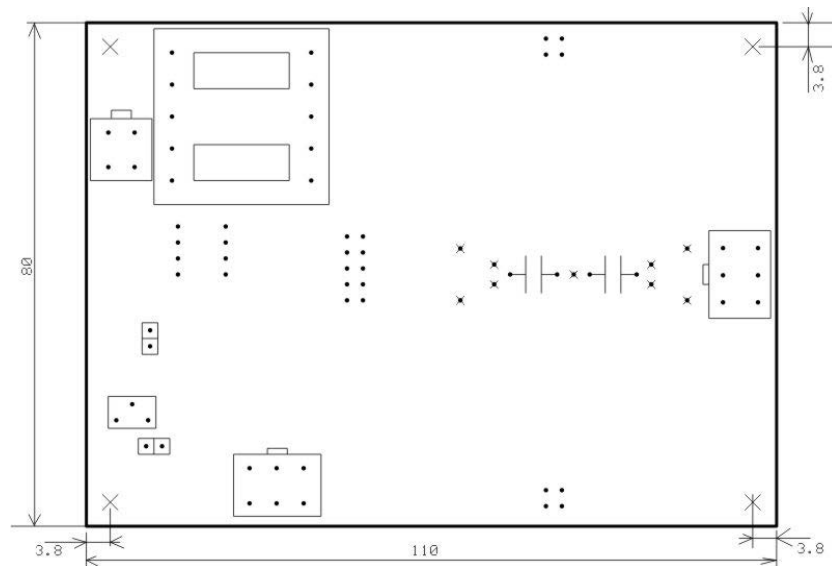

Part number table

Part Number	HVmax	HVmin
QBD-6024-DN QBD-6024-UP	6000	2400
QBD-5020-DN QBD-5020-UP	5000	2000
QBD-4016-DN QBD-4016-UP	4000	1600
QBD-3012-DN QBD-3012-UP	3000	1200
QBD-2008-DN QBD-2008-UP	2000	800
QBD-1004-DN QBD-1004-UP	1000	400

Suffics “DN” means pull-down scheme, “UP” – push-up scheme (see also *Pulse parameters* section)

Typical output

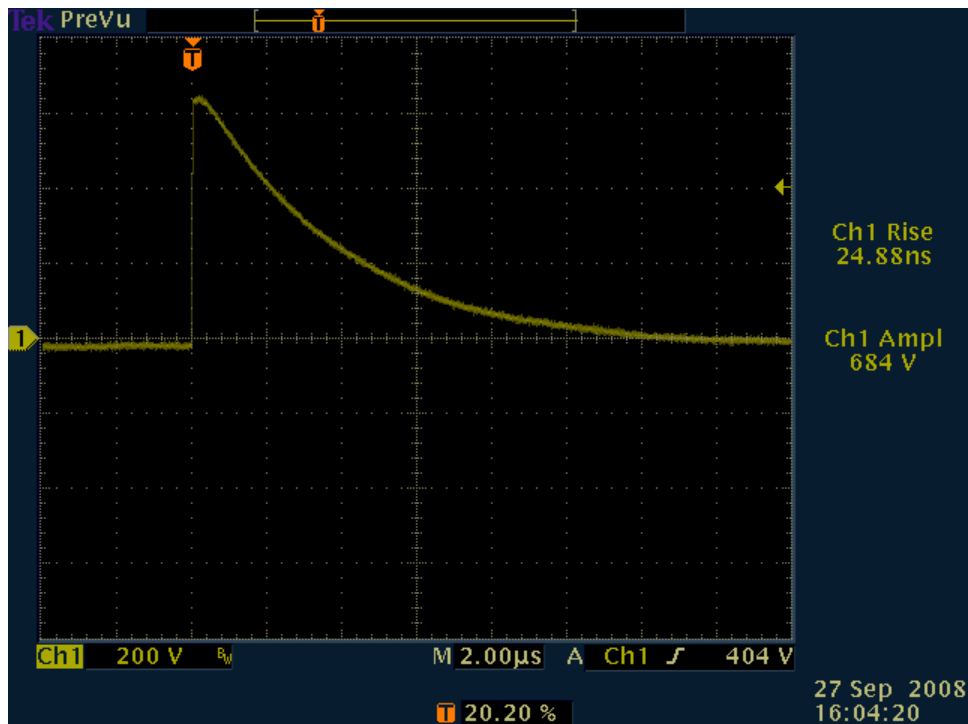

time scale: 2 μs / div

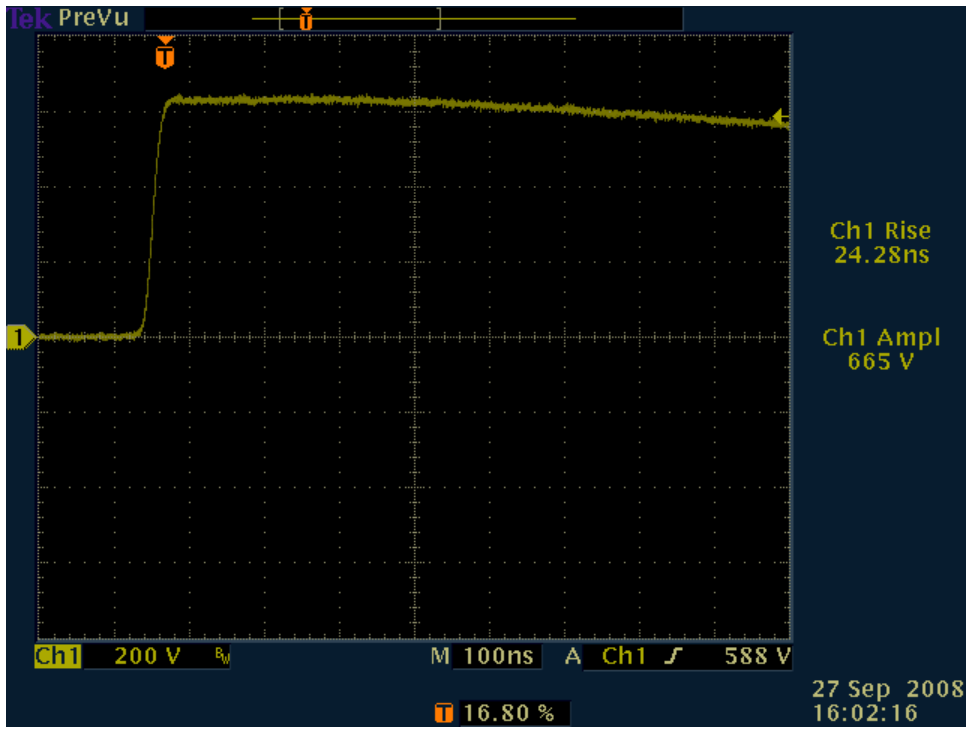

time scale: 100ns / div

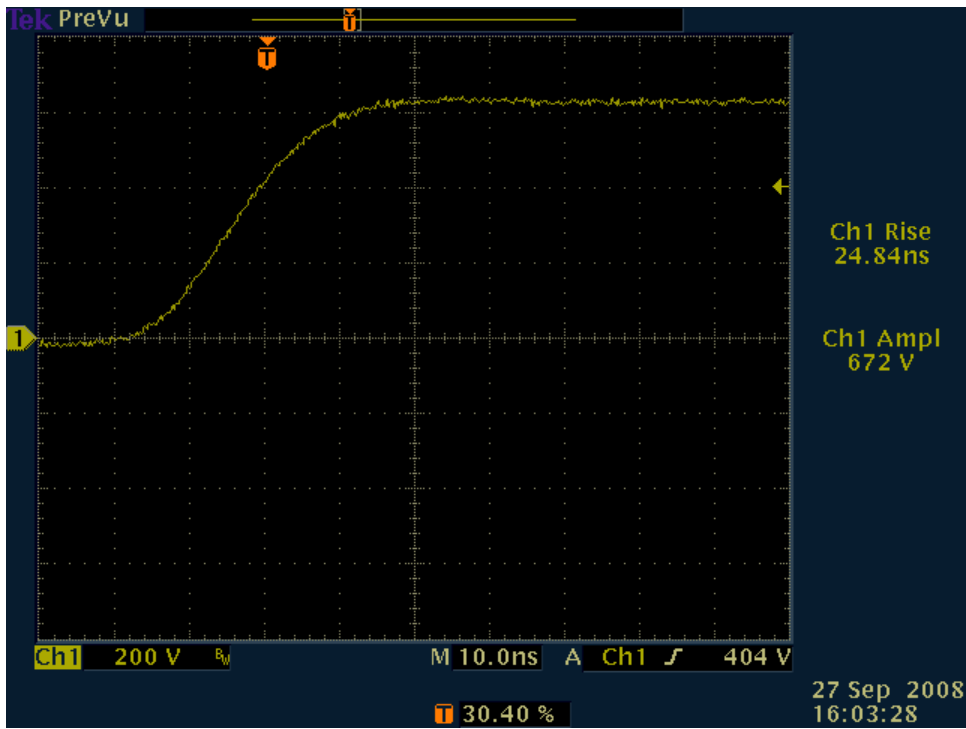

time scale: 10ns / div