

## QBU series Pockels cell driver

### User manual

**Warning!** This equipment produces high voltages that can be very dangerous. Please read user manual before starting operations.

**Important note:** please measure the output with symmetrical (differential) high voltage probe only. Measurement made with inappropriate equipment is a common cause of driver's failure.



## Overview

QBU series Pockels cell drivers produce high voltage pulses with high repetition rates, fast risetimes and falltimes, adjustable voltage amplitude and pulse width. Two control types are available: manual and automatic

## Pulse parameters

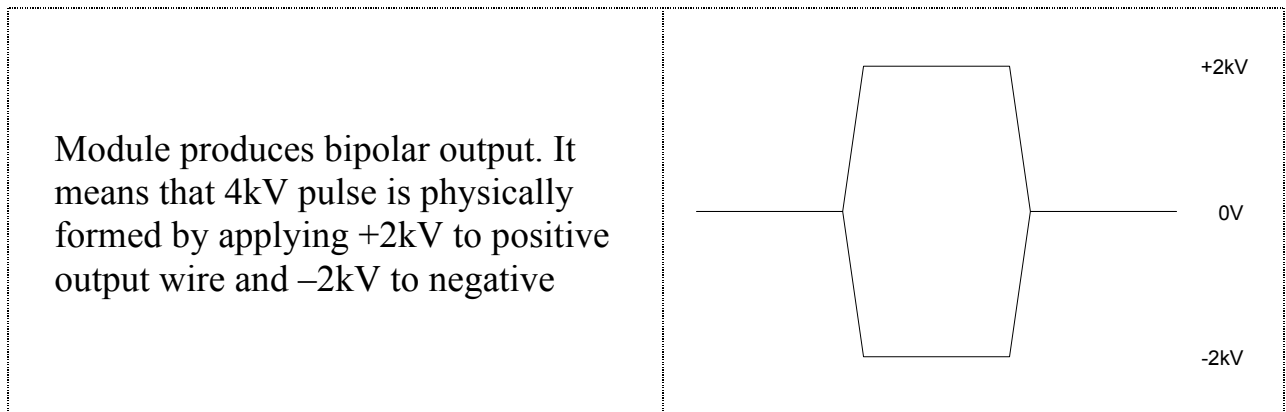

**Attention!** Further description of HV output will be given in terms of voltage differences. Please keep it in mind!

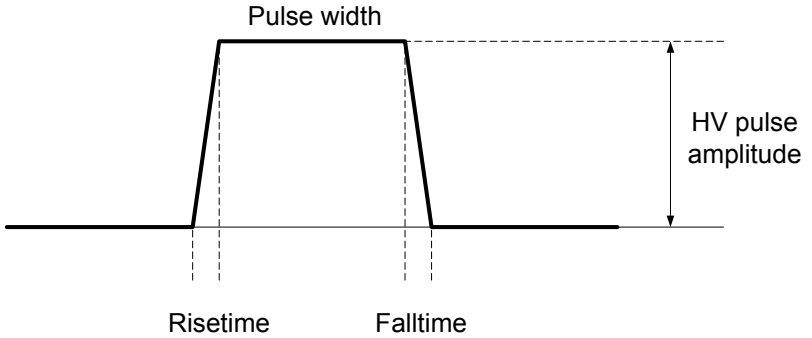
<p>Typical pulse shape</p>	
<p>Risetime / Falltime</p>	<p>&lt;15ns (about 10ns typ.)<sup>1, 2</sup></p>
<p>Pulse width</p>	<p>from 200ns to DC</p>
<p>HV pulse amplitude</p>	<p>from HV<sub>MIN</sub> to HV<sub>MAX</sub><sup>3</sup></p>
<p>Repetition rates</p>	<p>from single shot to ~50kHz (continuously)<sup>2, 4</sup>, to ~100kHz (short-term)<sup>2, 4</sup></p>
<p>Internal timing<sup>5</sup></p>	<p>~100us</p>

<sup>1</sup> at 10-90% level

<sup>2</sup> depends on HV pulse amplitude and load capacitance

<sup>3</sup> HV<sub>MIN</sub> and HV<sub>MAX</sub> values see in How to order? section

<sup>4</sup> depends on working mode and cooling conditions

<sup>5</sup> see description below

## Internal timing

---

Without Q-switch signal is switched driver maintains its state. Internal timer continuously refreshes driver condition every  $\sim 100\mu\text{s}$ . It is cause of:

1. HV output levels have small ripple with period  $\sim 100\mu\text{s}$
2. It's prohibited to trigger HV output level as internal timing is occurring.  
Therefore triggering of HV output is sometimes (very rarely) skipped.

## Cooling

---

At middle and high operation frequencies (more than 5-10kHz) forced air cooling is required. The driver has internal protection from overheating – it automatically shuts down at  $\sim 70\text{C}$

## Connections, signals, signal descriptions

---

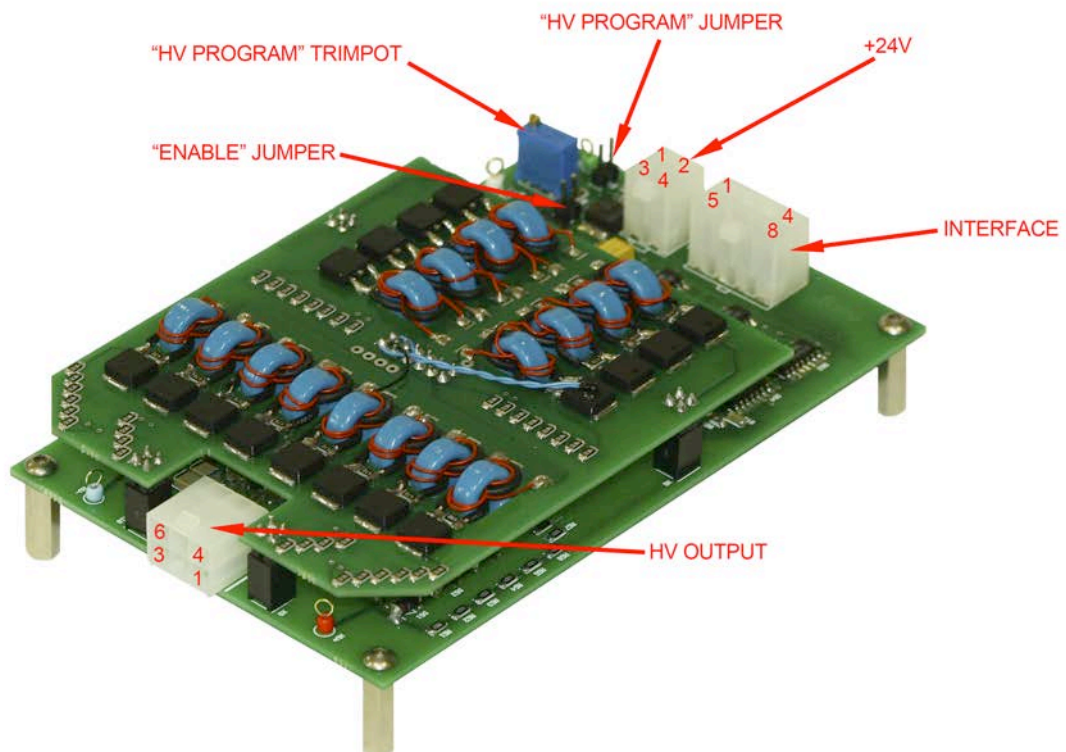

There are three connectors at Pockels cell “driver” board. Hereafter is description of corresponded female connectors (supplied with the board)

## INTERFACE (Molex 39-30-1060):

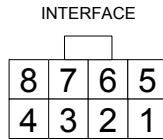

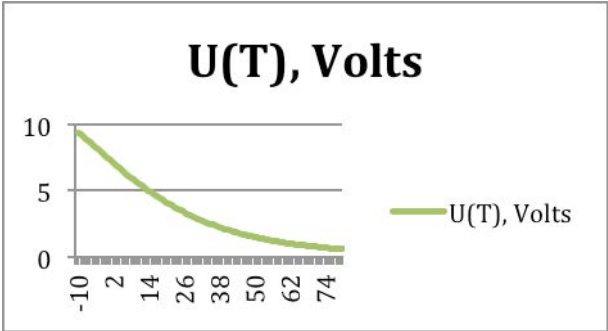
PIN (color)	DESIGNATION	DESCRIPTION
<b>1 (white)</b>	<b>Q-switch</b>	<p>While “0” or ”1” is applied to PIN1 high voltage output is maintained correspondingly at 0V or <b>HV</b> level</p> <p>Sequences of triggering pulses with period less than approx. 1us are ignored by driver</p>
<b>2 (violet)</b>	<b>Temp Monitor</b>	<p>This pin returns output voltage showing the internal temperature of the driver. Approximate U(T) dependence is given below.</p> <div style="text-align: center;">  <p><b>U(T), Volts</b></p> </div>
<b>3 (red)</b>	<b>+15 V</b>	Provides +15V DC level
<b>4 (blue)</b>	<b>Enable</b>	The high voltage output is enabled by PIN4 (“1” – enable, “0” – disable)
<b>5, 6 (black)</b>	<b>Interface Return</b>	PIN5 and PIN6 are connected to the circuit ground of all internal circuits
<b>7 (yellow)</b>	<b>HV Monitor</b>	<p>The voltage at PIN7 is a monitor signal proportional to the measured value of high voltage output</p> <p><b>HV<sub>MAX</sub></b> corresponds to 10V at PIN7, <b>HV<sub>MIN</sub></b> corresponds to approx. 4V at PIN7</p>
<b>8 (green)</b>	<b>HV Program</b>	<p>Positive DC voltage applied to PIN8 sets up high voltage value <b>HV</b></p> <p><b>HV<sub>MAX</sub></b> corresponds to 10V at PIN8, <b>HV<sub>MIN</sub></b> corresponds to approx. 4V at PIN8</p>

“0” means logical 0 low level (0V), “1” means logical 1 high level (5V)

## INTERFACE CIRCUITS

Q-Switch

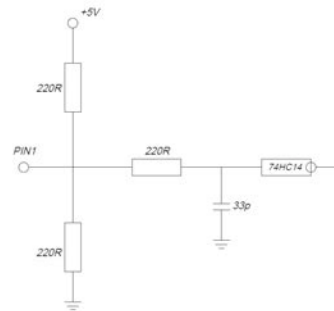

Enable

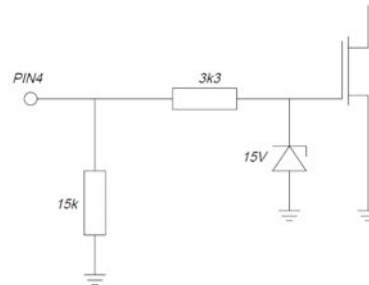

HV Program and HV Monitor

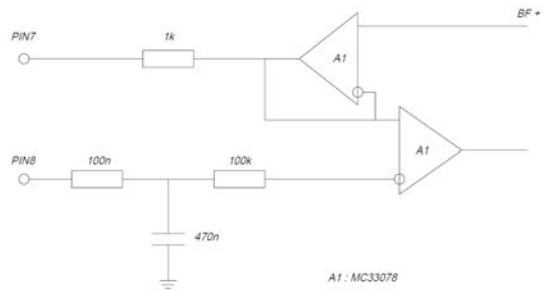

Temp Monitor

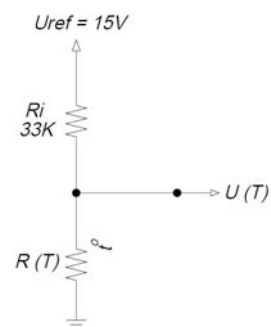

### +24V (Molex 39-30-1040):



PIN (color)	DESIGNATION	DESCRIPTION
1, 2 (red)	+24V	INPUT positive 24VDC for turn on the Pockels cell driver
3, 4 (black)	RETURN	Return from power supply producing +24VDC

### HV OUTPUT (Molex 39-30-1060):

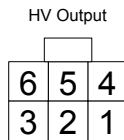

PIN (color)	DESIGNATION	DESCRIPTION
1, 4 (red)	Positive	HV Positive
2, 5	N/C	
3, 6 (blue)	Negative	HV Negative

### “ENABLE” JUMPER:

Use “ENABLE” JUMPER instead of “ENABLE” PIN4 of INTERFACE. Don’t use “ENABLE” JUMPER and “ENABLE” PIN at the same time.

### “HV PROGRAM” JUMPER AND “HV PROGRAM” TRIMPOD:

Use “HV PROGRAM” JUMPER instead of “HV PROGRAM” PIN8 of INTERFACE. If jumper is on it sets output voltage according to “HV PROGRAM” TRIMPOD state.

Don’t use “HV PROGRAM” JUMPER and “HV PROGRAM” PIN at the same time.

## Safety

---

**Warning!** This equipment produces high voltages that can be very dangerous. Don't be careless around this equipment.

- To provide safety the QBU-series Pockels cell driver module is designed to be powered with supply voltage +24VDC, which must be galvanically separated from mains.
- It is the user's responsibility to ensure that personnel are prevented from accidentally contacting the QBU-series Pockels cell driver module, especially the high voltage connector and cable. **Casual contact could be fatal.** Output cables must have good isolation for output voltage and low capacitance.
- After shut down, do not touch the load until it has been discharged. Use an appropriate measurement device to check for complete discharge.
- Disconnect the QBU-series Pockels cell driver module from DC power supply before changing electrical or mechanical connections.

## Operations (Manual control)

---

1. Connect +24VDC power supply, pulse generator and Pockels cell
2. Set up "*HV PROGRAM*" JUMPER
3. Turn on +24VDC power supply
4. Set up "*ENABLE*" JUMPER
5. Use "*HV PROGRAM*" TRIMPOD to set up required output voltage
6. Send driving pulses from pulse generator to *PINI* of *INTERFACE*.  
Set both pulse length and distance between pulses not less than 1us
7. To power down the driver, turn off +24VDC power supply or remove "*ENABLE*" JUMPER

## Operations (Automatic control)

---

1. Connect +24V, *INTERFACE* and *HV OUTPUT* connectors to the board.
2. Remove "*HV PROGRAM*" JUMPER, remove "*ENABLE*" JUMPER
3. *DISABLE* the high voltage output
4. Apply the correct nominal *DC INPUT* power to the module
5. Set up the required output voltage by applying a DC voltage to the *HV PROGRAM PIN8* of *INTERFACE*
6. *ENABLE* the high voltage output
7. Send driving pulses to *PINI* of *INTERFACE*.  
Too short pulses will be processed as 200ns pulses
8. To power down the driver, remove *DC INPUT* power or *DISABLE* high voltage output

## Measure the output voltage

---

**Important note:** please measure the output with symmetrical (differential) high voltage probe only. Measurement made with inappropriate equipment is a common cause of driver's failure.



## Specification

---

### ELECTRICAL SPECIFICATION

<b>Input:</b>	+24V DC; 0.8A max
<b>Output:</b>	
HV pulse amplitude	Adjustable in HV <sub>MIN</sub> to HV <sub>MAX</sub> range (see How to order? section for the details)
HV basement level	0V, fixed
Pulse width	From 200ns to DC
Risetime / falltime	~10ns (10-90% level, warranted at load capacitance 11pF and below)
Jitter	± 10ns (± 1ns in LJ-modification)
Delay time	1us (100ns in LJ-modification)
Repetition rate	Up to 100kHz (see Performance section for details)
<b>Cooling:</b>	Forced air cooling at high repetition rates
<b>Environment</b>	
Operation temperature	+10...+40 C
Storage temperature	-20...+60 C
Humidity	90%, non-condensing

### MECHANICAL SPECIFICATION

Size (LxWxH)	130x80x25 mm
Weight	0,1 kg



## DRAWINGS

---

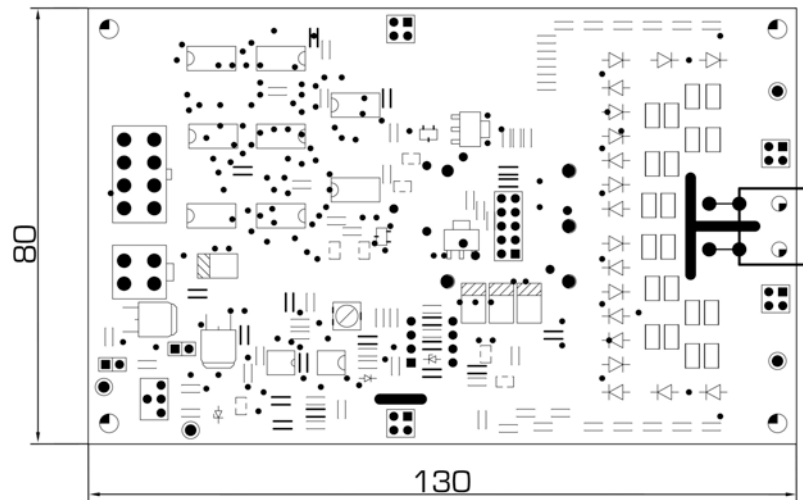

### How to order?

---

QBU-XXYY-ZZ, where

XX codes the maximal output voltage ( $V_{MAX}$ , user selectable up to 6000V), YY codes the minimal output voltage ( $V_{MIN}$ , 40% of  $V_{MAX}$ ).

ZZ codes options:

LJ – low jitter option (mandatory for 6kV modification, optional for others) – jitter is as low as  $\pm 1$ ns, delay time is as short as 100ns;

Examples (the most popular modifications):

Part number	HV <sub>MAX</sub>	HV <sub>MIN</sub>
QBU-6024-LJ	6000V	2400V
QBU-5020 QBU-5020-LJ	5000V	2000V
QBU-4016 QBU-4016-LJ	4000V	1600V
QBU-3012 QBU-3012-LJ	3000V	1200V
QBU-2008 QBU-2008-LJ	2000V	800V
QBU-1004 QBU-1004-LJ	1000V	400V

Other modifications are available on request.

## Performance

---

For continuous operation **with the appropriate cooling** we warrant the performance table as follows:

11 pF load capacitance								
Voltage, kV	2.0	2.5	3.0	3.5	4.0	4.5	5.0	6.0
Max. rep. rate, kHz	56	40	31	24	18	15	12	9

In the burst-mode (= short time operations) performance is increasing approximately twice and may achieve 100kHz value at low operating voltage and low load capacitance.

Higher load capacitance decreases the performance.

**Note:** modules with the higher performance are available on request

## Typical output

QBU-6024-LJ, Capacitance load 11pF + HV Probe (about 13pF), 6kV pulses

